

retigo®

Steam Combi Oven

THE HEART OF THE MODERN KITCHEN



RETIGO DIGITAL 6 x GN1/1

The following is characteristic of all models:

- Electronic, microprocessor control system
- Simple, intuitive operation with display of basic functions
- Hygienic cooking chamber with rounded inside corners
- Even baking thanks to the bi-directional fan
- Perfect illumination of the cooking chamber by means of halogen lights
- Double glass door that limits the escape of heat
- Run-off tray under the door for collecting condensed water
- Removable door seal for easy maintenance
- Core temperature probe offered on all models
- WSS - water saving system prevents high water consumption in all cooking modes
- Two position door catch (safety position)
- Integrated shower for easy cleaning which does not use softened water
- SDS - service and diagnostic system - automatic evaluation of microprocessor error reports
- IPX5 shield
- BCS - boiler control system *
- CCS - calcium control system *

*only boiler steam combi ovens

PRACTIC pi, pb, pg

- Hot air 30 - 280°C
- Combination 50 - 280°C
- Steaming 99 - 130°C
- BIO steaming 30 - 98°C
- Regeneration
- Manual moistening
- Time setting from 1 min. to 24 hrs.
- Permanent light mode

OPTIONAL:

- Flap valve
- Core temperature probe
- HACCP set

STANDARD si, sb, sg

- Hot air 30 - 280°C
- Combination 50 - 280°C
- Steaming 99 - 130°C
- BIO steaming 30 - 98°C
- Regeneration
- Manual moistening
- Time setting from 1 min. to 24 hrs.
- Permanent light mode
- Core temperature probe
- 100 programs with 5 steps
- Autoklima - control of steam saturation
- Automatic start mode
- Rapid cooling of the cooking chamber
- ON/OFF mode

OPTIONAL:

- Flap valve
- HACCP set

COMFORT ci, cb, cg

- Hot air 30 - 280°C
- Combination 50 - 280°C
- Steaming 99 - 130°C
- BIO steaming 30 - 98°C
- Regeneration
- Manual moistening
- Time setting from 1 min. to 24 hrs.
- Permanent light mode
- Three point core temperature probe
- 200 programs with 5 steps
- Autoklima - control of steam saturation
- Graphic display
- ACM (automatic capacity management)
- Low temperature roasting/cooking
- Delta T roasting/cooking
- Setting of fan cycle
- Flap valve
- PC jack
- Quick view
- Automatic start mode
- Rapid cooling of the cooking chamber
- Display of program in use
- Two speed motor
- ON/OFF mode

OPTIONAL:

- Winding shower
- Active (Automatic) Cleaning
- HACCP set

g - gas combi oven

i - direct steam generation

b - steam generation in boiler

retigo®

Steam Combi Oven

THE HEART OF THE MODERN KITCHEN

Electric combi oven 6 x GN1/1 – pi, si, ci, pb, sb, cb

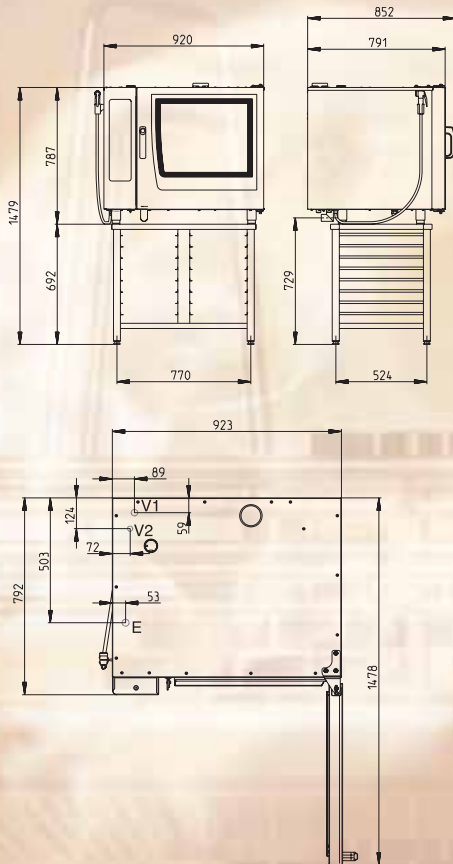

Gas combi oven 6 x GN1/1 – pg, sg, cg

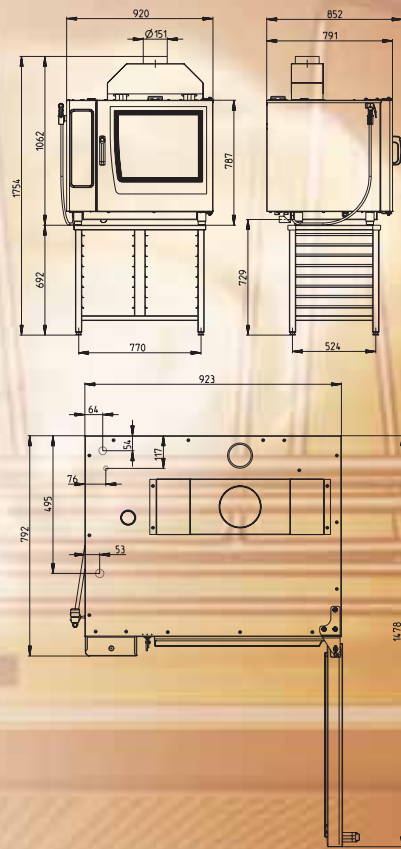

V1 – soft water inlet, V2 – hard water inlet, E – electricity

Model	611 pi, si, ci	611 pb, sb, cb	611 pg, sg, cg
Energy	electric	electric	gas
Steam generation	direct injection	boiler	direct injection
Capacity	6 x GN1/1	6 x GN1/1	6 x GN1/1
Capacity of meals	50 - 150	50 - 150	50 - 150
Spacing	65 mm	65 mm	65 mm
Dimensions (WxHxD)	920 x 787 x 791 mm	920 x 787 x 791 mm	920 x 1062 x 791 mm
Weight	110 kg	110 kg	110 kg
Total power	10.2 kW	10.2 kW	
Steady state power	3000 W	3000 W	
Steam generation power		9 kW	
Heat power			14 kW
Electro-power			800 W
Gas consumption			1.4 m ³ /hr
Fuse protection	16 A	16 A	16 A
Voltage	3N~/400V/50Hz	3N~/400V/50Hz	1N~/230V/50Hz
Water connection/drain	G 3/4" / 40 mm	G 3/4" / 40 mm	G 3/4" / 40 mm
Gas connection			G 3/4"
Temperature	30 - 280°C	30 - 280°C	30 - 280°C

Accessories for RETIGO DIGITAL 6 x GN1/1: GN holders

Optional: ST 1116 stainless steel stand for 16 GN1/1, STO 1116 stainless steel stand for 16 GN1/1 sheathed

RETIGO Ltd.,

Láň 2310, PS 43, 756 64 Rožnov pod Radhoštěm, Czech Republic, tel/fax: +420 571 652 434, info@retigo.cz, www.retigo.com